

2" ADJUSTABLE FITTER

# RUUD 22" (559mm) VERTICAL PARKING/ROADWAY

VPR3-22 SERIES

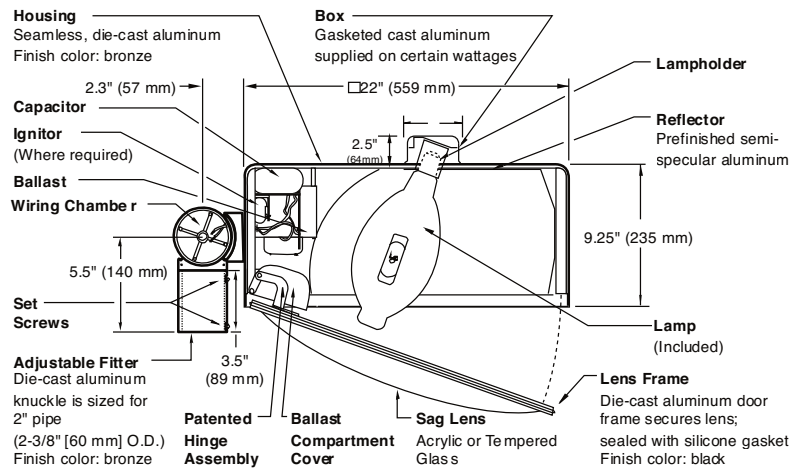

## FEATURES

70° main beam wide forward throw luminaire for 20° from vertical HID lamp, totally enclosed. Optics provide precise control with low nadir candlepower. Housing is seamless die-cast aluminum. Aluminum die-cast adjustable fitter mounting is sized for 2" pipe (2-3/8" [60 mm] O.D.). Allows for directional aiming as well as 2-1/2° incremental vertical adjustment. Contains integral wiring compartment. Two stainless-steel set screws provide clamping to vertical tenons. Gasketed, cast aluminum box supplied on top of 750, 875 and 1000W PSMH, 1000W MH, 250 and 400W HPS housing for tilted lamp clearance. Lens assembly consists of a rigid die-cast aluminum frame and clear acrylic sag lens (tempered glass on 450, 750, 875 and 1000W PSMH and 1000W MH). Fixture supplied with 36" (914 mm) flexible cord, hardware supplied by others.

## ELECTRICAL SPECIFICATIONS

Fixture includes a clear, mogul-base lamp. 300 through 400W PSMH and 400W MH utilize the ED28 reduced envelope lamp. 450, 875 and 1000W PSMH and 1000W MH utilize the BT37 reduced envelope lamp. Pulse-rated porcelain enclosed, 4kv (5kv for 750 & 1000W PSMH) rated screw-shell-type lampholder with spring-loaded center contact and lamp grips. Lamp ignitor included where required. All ballast assemblies are high-power factor.

## LABELS

ANSI lamp wattage label supplied, visible during relamping. UL Listed in US and Canada for wet locations and enclosure classified IP54 per IEC 529 and IEC598.

## FINISH

Exclusive DeltaGuard® finish features an E-coat epoxy primer with ultra-durable powder topcoat, providing excellent resistance to corrosion, ultraviolet degradation and abrasion. The finish is covered by our seven year limited warranty.

## PATENTS

US 4,689,729.

## WATTAGE

## CATALOGUE #

### PULSE START METAL HALIDE

200W PSMH	VPR36920-(a) (b)
250W PSMH	VPR36925-(a) (b)
300W PSMH	VPR36930-(a) (b)
320W PSMH	VPR36932-(a) (b)
350W PSMH	VPR36935-(a) (b)
⚡ 400W PSMH	VPR36940-(a) (b)
450W PSMH	VPR36945-(a) (b)
750W PSMH	VPR3675-(a) (b)
875W PSMH	VPR3687-(a) (b)
1000W PSMH	VPR3699-(a) (b)

### METAL HALIDE

250W MH	VPR3492-(a) (b)
400W MH	VPR3494-(a) (b)
1000W MH	VPR3499-(a) (b)

### HIGH PRESSURE SODIUM

250W HPS	VPR3592-(a) (b)
400W HPS	VPR3594-(a) (b)

⚡ 2L level available – consult factory.

⚡ Reduced envelope lamp; ED28 for 300 through 400W PSMH and 400W MH; BT37 for 450, 875 and 1000W PSMH and 1000W MH.

## OPTIONS (factory-installed)

-(a)F	Fusing
Q	Quartz Standby (includes 100W quartz lamp)

## ACCESSORIES

SBL-22 Backlight Shield



ISOFOOTCANDLE PLOTS

Isofootcandle plots show initial footcandles at grade. (Footcandles ÷ 0.0929 = Lux)

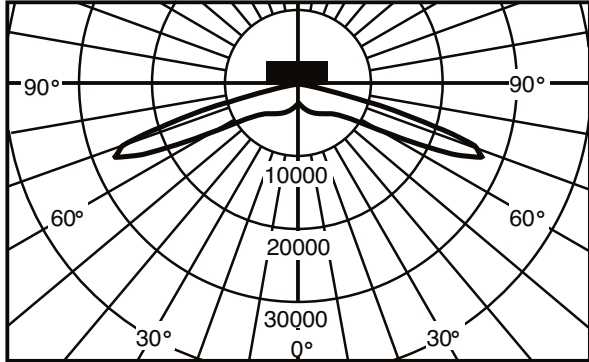

Candlepower distribution curve of 400W PSMH Vertical Parking/Roadway

Light Lighting Sciences Inc. Certified Test Report No. 13844

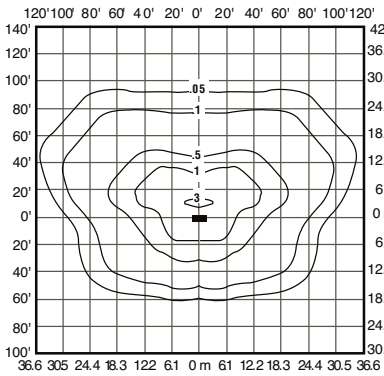

Isofootcandle plot of one 250W MH Vertical Parking/Roadway Light at 25' (7.6 m) mounting height and 0° vertical tilt. (Plan View)

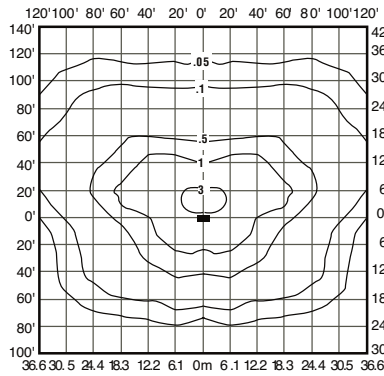

Isofootcandle plot of one 400W MH Vertical Parking/Roadway Light at 30' (9.1 m) mounting height and 0° vertical tilt. (Plan View)

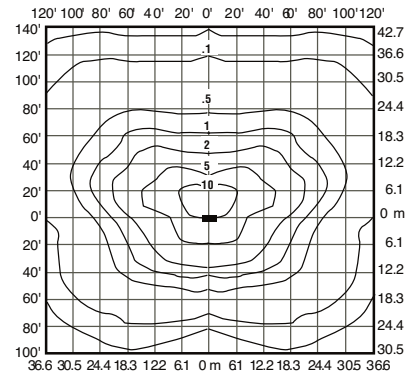

Isofootcandle plot of one 1000W MH Vertical Parking/Roadway Light at 25' (7.6 m) mounting height and 0° vertical tilt. (Plan View)

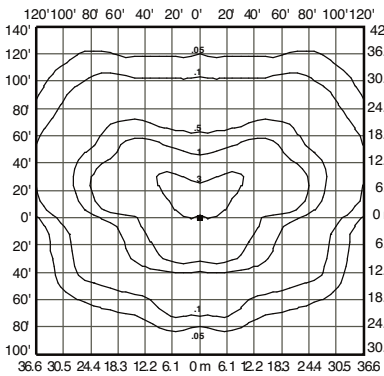

Isofootcandle plot of one 400W PSMH Vertical Parking/Roadway Light at 30' (9.1 m) mounting height and 0° vertical tilt. (Plan View)

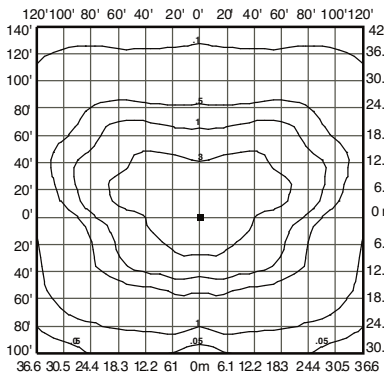

Isofootcandle plot of one 1000W PSMH Vertical Parking/Roadway Light at 30' (9.1 m) mounting height and 0° vertical tilt. (Plan View)